

Article number: 230100044511
 Description: E+G Crank handle
 MT.160 AS-17x17-SI

Measures

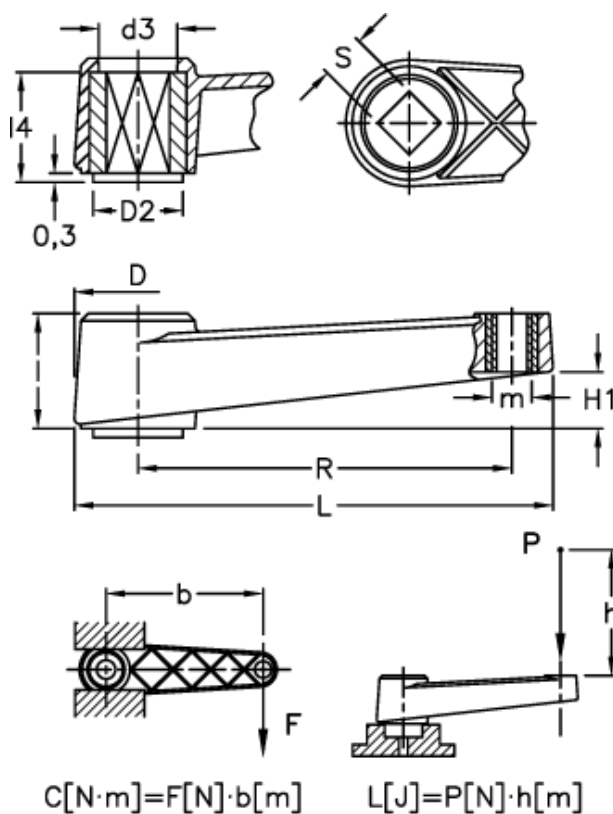

C (N m) = 450	l4 = 34
D = 45	m = M10
d2 = 30	R = 160
d3 = 27	S H9 = 17x17
H1 = 23	
l = 40	
L = 198	
L(J) = 55	